

Overview

The GFD module is designed to detect ground fault conditions on either of two independent power or data circuits. Each circuit must be balanced with respect to ground.

The module will detect when the resistance between any of the monitored conductors and earth ground gets below 10 K Ohms. Two LEDs are provided to indicate the conductor with the ground condition. A normally energized Trouble/Ground Fault relay is provided with NO/NC relay contacts for interfacing with monitoring systems. Either of two operating modes is selected by jumper selection.

Mode 1 places a ground fault on the common terminal of the relay. When used with a Signature input module, this configuration provides independent indications of ground fault and GFD module trouble conditions at the control panel.

Mode 2 de-activates the normally energized relay contact upon ground fault or module trouble.

The ground fault relay activates when any monitored conductor experiences a ground fault condition. The trouble relay operates when module power is not available or the supervisory watchdog timer activates.

The module is designed to mount in a 2-gang electrical box.

Standard Features

- Monitors two independent circuits
- Suitable for all power limited circuits
- Provides separate ground fault and trouble indication when used with Signature input modules
- Provides form C relay contact
- Supervised
- In and out terminals for convenient wiring
- Mounts in 2-gang electrical box

Ground Fault Detection Module

GFD



Application

The GFD module is designed to operate with short haul modems and other power limited circuits requiring the detection of ground fault conditions on its conductors.

When used with Signature series input modules, separate indications of ground fault and module trouble can be annunciated at the control panel (mode1). The module's relay contacts are also suitable for monitoring by systems not capable of independently reporting grounded conditions by using mode 2.

Engineering Specification

The ground fault detection module shall be supplied on network communication circuits not employing integral ground fault detection. Detection of a ground fault condition shall transfer the module's relay contacts.

Mounting

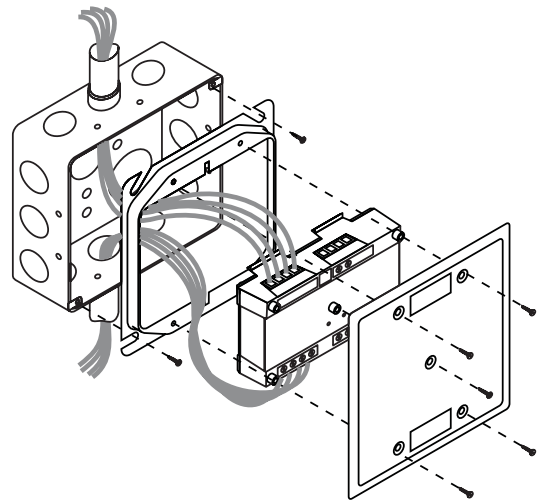

Typical Wiring

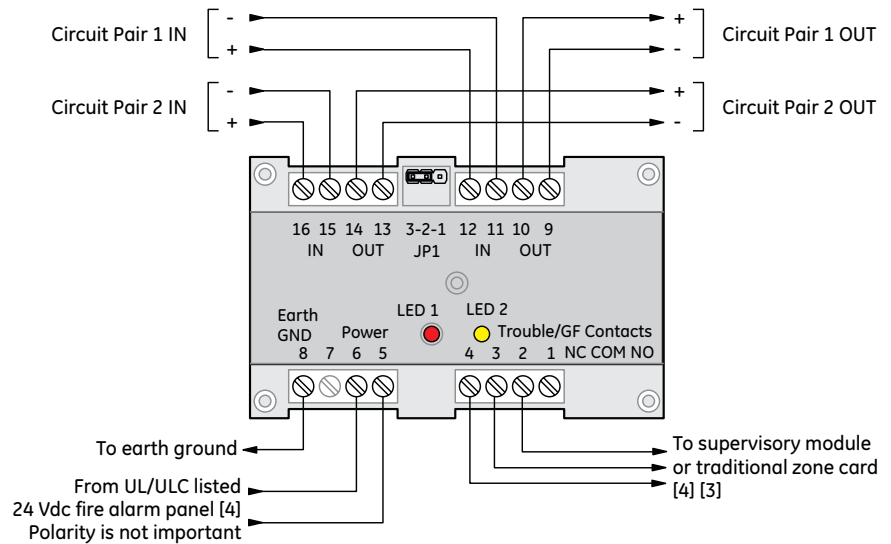

Notes

1. All circuits are power-limited and supervised, unless otherwise noted
2. Contact 7 is not used
- [3] The functionality of the Trouble/GF circuit is dependent on the position of JP1. See "Jumper setup" on installation sheet 387630 for details.
- [4] Use a UL/ULC listed end-of-line device for complete supervision. Contacts cannot be used for nonpower-limited applications unless all wiring is type FPL, FPLR, or FPLP.

Specifications

Agency Listings	UL, ULC
Installation	Connects to both conductors of the monitored circuit(s).
Ground fault condition	Less than 10KOhms between any monitored conductor and the reference ground
Monitored Circuit(s) Configuration	Monitored circuit(s) must have both conductors balanced with respect to ground
	Max voltage 100 Vdc
	Max current 4.0 A
	Max voltage between monitored circuits 1000 Vdc
Power Consumption	110mA @ 24V. Power is isolated from monitored circuits.
Trouble/Ground Fault Relay	Output operation is jumper configurable
	Mode 1 Places a ground fault on the common terminal of the relay for detection by a Signature module.
	Mode 2 Normally energized NO/NC contact de-activates upon module trouble or ground fault.
	Contact rating 1.0A @ 30 Vdc
Mounting	
	Compatible Electrical Boxes North American 2-1/2" (64mm) Deep 2-Gang Box Standard 4" Square Box 1-1/2" (38mm) Deep Box with 2-gang cover
	Mounting Brackets SIGA-MP1, SIGA-MP2(L)
Visual Indicators	Two LEDs indicate which of the four conductors are grounded.
Terminations	All wiring to terminals that accept #18 AWG to #12 AWG conductors
Operating environment	32°F -120°F (0°C - 49°C) @93% RH, Non-condensing

Ordering Information

Catalog Number	Description	Shipping Wt., lb (kg)
GFD	Ground Fault Detection Module	1 (.45)
MFC-A	Multifunction Fire Cabinet - Red, supports Signature Module Mounting Plates	7.0 (3.1)
SIGA-MP1	Signature Module Mounting Plate, 1 footprint	1.5 (0.70)
SIGA-MP2	Signature Module Mounting Plate, 1/2 footprint	0.5 (0.23)
SIGA-MP2L	Signature Module Mounting Plate, 1/2 extended footprint	1.02 (0.46)

GE Security

U.S.
T 888-378-2329
F 866-503-3996

Canada
T 519 376 2430
F 519 376 7258

Asia
T 852 2907 8108
F 852 2142 5063

Australia
T 61 3 9259 4700
F 61 3 9259 4799

Europe
T 32 2 725 11 20
F 32 2 721 86 13

Latin America
T 305 593 4301
F 305 593 4300

www.gesecurity.com/est

© 2008 General Electric Company
All Rights Reserved



imagination at work