

Overview

The SIGA-MM1 Monitor Module and SIGA-WTM Waterflow/Tamper Module are part of GE Security's Signature Series system. They are intelligent analog addressable devices used to connect one or two Class B normally-open Alarm, Supervisory, or Monitor type dry contact Initiating Device Circuits (IDC). The function of the SIGA-MM1 and SIGA-WTM is determined by the factory loaded "personality code".

The input modules gather analog information from the initiating devices connected to them and convert it into digital signals. The module's on-board microprocessor analyzes the signal and decides whether or not to input an alarm.

The microprocessor in each module provides four additional benefits - Self-diagnostics and History Log, Automatic Device Mapping, Stand-alone Operation and Fast, Stable Communication.

Standard Features

- **Monitor and waterflow/tamper applications**
Includes Alarm with delayed latching (retard) for waterflow applications, Supervisory, and Monitor.
- **Non-volatile memory**
Permanently stores serial number, type of device, and job number. Automatically updates historic information including hours of operation, last maintenance date, number of alarms and troubles, and time and date of last alarm.
- **Automatic device mapping**
Each module transmits wiring information to the loop controller regarding its location with respect to other devices on the circuit.
- **Electronic addressing**
Permanently stores programmable address; there are no switches or dials to set. Addresses are downloaded from a PC, or the SIGA-PRO Signature Program/Service Tool.
- **Intelligent module c/w integral microprocessor**
All decisions are made at the module allowing lower communication speed while substantially improving control panel response time. Less sensitive to line noise and circuit wiring properties; twisted or shielded wire is not required.
- **Ground fault detection by address**
Detects ground faults right down to the device level.
- **Designed for high ambient temperature operation**
Install in ambient temperatures up to 120°F (49°C).

Input Modules

SIGA-MM1 & SIGA-WTM



Application

The duty performed by the SIGA-MM1 and SIGA-WTM is determined by their factory assigned sub-type code or "Personality Code".

SIGA-WTM NORMALLY-OPEN ALARM - DELAYED LATCHING (Factory set Personality Code 2) - Assigned to one circuit. Configures circuit 1 for **Class B** normally-open **Waterflow Alarm Switches**. An ALARM signal is sent to the loop controller when the input contact is closed for approximately 16 seconds. The alarm condition is latched at the module.

SIGA-WTM NORMALLY-OPEN ACTIVE - LATCHING (Factory set Personality Code 4) - Assigned to one circuit. Configures circuit 2 for **Class B** normally open dry contact **Supervisory and Tamper Switches**. An ACTIVE signal is sent to the loop controller when the input contact is closed. The active condition is latched at the module.

SIGA-MM1 NORMALLY-OPEN ACTIVE - NON-LATCHING (Factory set Personality Code 3) - Assigned to one circuit. Configures circuit 1 for **Class B** normally-open dry contact monitoring input such as from **Fans, Dampers, Doors**, etc. An ACTIVE signal is sent to the loop controller when the input contact is closed. The active condition is not latched at the module. Compatibility

The Signature Series modules are compatible only with GE Security's Signature Loop Controller.

Warnings & Cautions

This module will not operate without electrical power. As fires frequently cause power interruption, we suggest you discuss further safeguards with your local fire protection specialist.

Testing & Maintenance

The module's automatic self-diagnosis identifies when it is defective and causes a trouble message. The user-friendly maintenance program shows the current state of each module and other pertinent messages. Single modules may be turned off (de-activated) temporarily, from the control panel. Scheduled maintenance (Regular or Selected) for proper system operation should be planned to meet the requirements of the Authority Having Jurisdiction (AHJ). Refer to current NFPA 72 and ULC CAN/ULC 536 standards. Availability of maintenance features is dependent on the fire alarm system used.

Installation

The SIGA-MM1 and SIGA-WTM modules mount to North American 2-1/2 inch (64 mm) deep one-gang boxes and 1-1/2 inch (38 mm) deep 4 inch square boxes with one-gang covers and SIGA-MP mounting plates. The terminals are suited for #12 to #18 AWG (2.5 mm² to 0.75 mm²) wire size.

GE Security recommends that this module be installed according to latest recognized edition of national and local fire alarm codes.

Electronic Addressing - The loop controller electronically addresses each module, saving valuable time during system commissioning. Setting complicated switches or dials is not required. Each module has its own unique serial number stored in its on-board memory. The loop controller identifies each device on the loop and assigns a "soft" address to each serial number. If desired, the modules can be addressed using the SIGA-PRO Signature Program/Service Tool.

Personality codes are assigned by the factory. No user configuration is required for these modules.

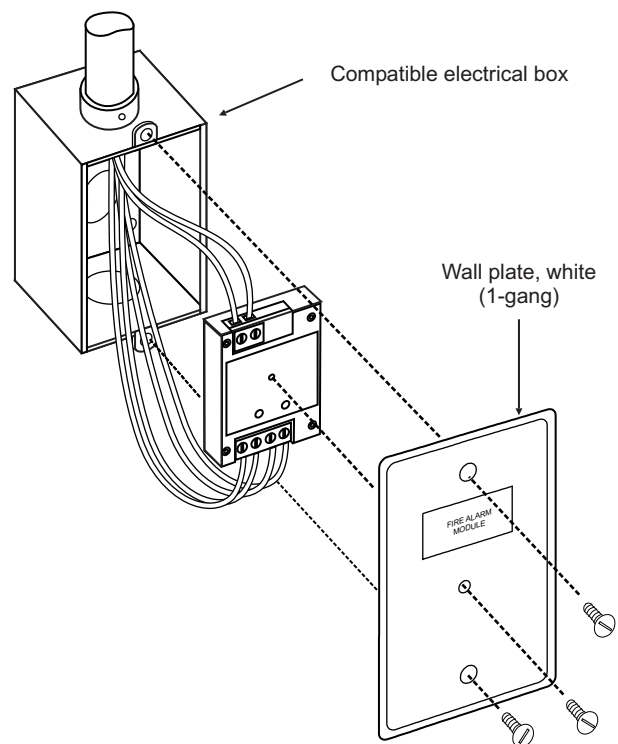

Typical Wiring

The module will accept #18 AWG (0.75mm²), #16 (1.0mm²), #14 AWG (1.50mm²), #12 AWG (2.50mm²) wire sizes.

Note: Sizes #16 AWG (1.0mm²) and #18 AWG (0.75mm²) are preferred for ease of installation. See Signature Loop Controller catalog sheet for detailed wiring requirement specifications.

Initiating (Slave) Device Circuit Wire Specifications

Maximum Allowable Wire Resistance 50 ohms (25 ohms per wire) per Circuit

Maximum Allowable Wire Capacitance 0.1µF per Circuit

For Design Reference:

Wire Size

Maximum Distance to EOLR

#18 AWG (0.75 mm²)

#16 AWG (1.00 mm²)

#14 AWG (1.50 mm²)

#12 AWG (1.50 mm²)

4,000 ft (1219 m)

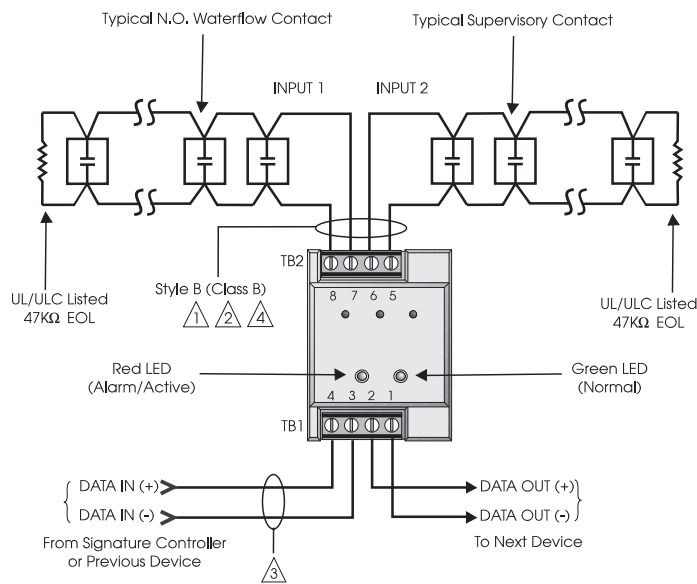

Model SIGA-WTM

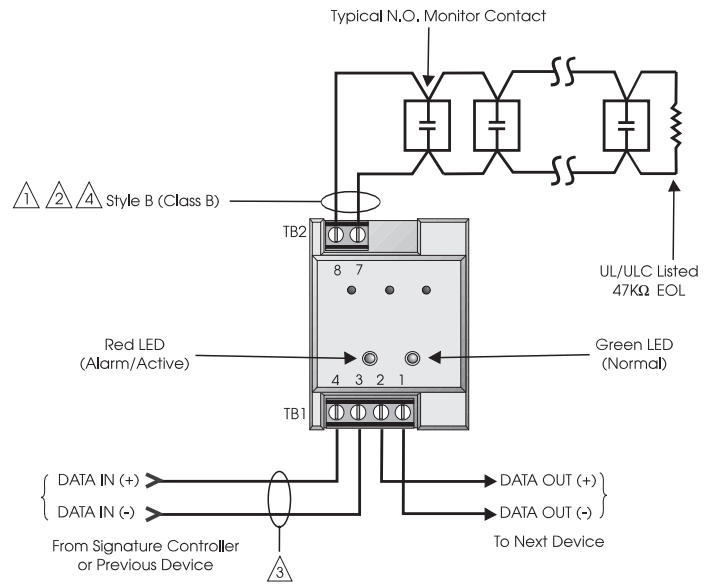

Model SIGA-MM1

Notes

- 1 Maximum 25 ohms resistance per wire.
- 2 Maximum #12 AWG (2.5mm²) wire. Min. #18 (0.75mm²)
- 3 Refer to Signature Loop Controller Installation Sheet for wiring specifications.
- 4 Maximum 10 Vdc @ 350µA.
- 5 All wiring power limited and supervised.
- 6 This module will NOT support 2-wire smoke detectors.

U.S.
T 888-378-2329
F 866-503-3996

Canada
T 519 376 2430
F 519 376 7258

Asia
T 852 2907 8108
F 852 2142 5063

Australia
T 61 3 9259 4700
F 61 3 9259 4799

Europe
T 32 2 725 11 20
F 32 2 721 86 13

Latin America
T 305 593 4301
F 305 593 4300

www.gesecurity.com/est

© 2006 General Electric Company
All Rights Reserved

Signature Series is a Trademark
of GE Security.

Specifications

Catalog Number	SIGA-MM1	SIGA-WTM
Description	Monitor Module	Waterflow/Tamper Module
Type Code	48 (factory set personality code 3)	49 (factory set personality code 2,4)
Address Requirements	Uses One Module Address	Uses Two Module Addresses
Operating Current	Standby = 250µA; Activated = 400µA	Standby = 396µA; Activated = 680µA
Operating Voltage	15.2 to 19.95 Vdc (19 Vdc nominal)	
Construction & Finish	High Impact Engineering Polymer one-gang front plate - White	
Storage and Operating Environment	Operating Temperature: 32°F to 120°F (0°C to 49°C) Storage Temperature: -4°F to 140°F (-20°C to 60°C) Humidity: 0 to 93% RH	
LED Operation	On-board Green LED - Flashes when polled On-board Red LED - Flashes when in alarm/active Both LEDs - Glow steady when in alarm (stand-alone)	
Compatibility Agency Listings	Use With Signature Loop Controller UL, ULC, CSFM, MEA	
Mounting	North American 2-1/2 inch (64 mm) deep one-gang boxes and 1-1/2 inch (38 mm) deep 4 inch square boxes with one-gang covers and SIGA-MP mounting plates.	

Ordering Information

Catalog Number	Description	Ship Wt lbs (kg)
SIGA-MM1	Monitor Module - UL/ULC Listed	0.4 (.15)
SIGA-WTM	Waterflow/Tamper Module - UL/ULC Listed	

Accessories		
Catalog Number	Description	Ship Wt lbs (kg)
27193-11	Surface Mount Box - Red, 1-gang	1.0 (0.6)
27193-16	Surface Mount Box - White, 1-gang	
MFC-A	Multifunction Fire Cabinet - Red, supports Signature Module Mounting Plates	7.0 (3.1)
SIGA-MB4	Transponder Mounting Bracket (allows for mounting two 1-gang modules in a 2-gang box)	0.4 (0.15)
SIGA-MP1	Signature Module Mounting Plate, 1 footprint	1.5 (0.70)
SIGA-MP2	Signature Module Mounting Plate, 1/2 footprint	0.5 (0.23)
SIGA-MP2L	Signature Module Mounting Plate, 1/2 extended footprint	1.02 (0.46)



imagination at work