

Overview

The GE Security 5530MD-24AW Adaptatone Millennium is a heavy-duty industrial, tone-selectable, stand-alone, signaling device capable of producing volume-controlled, high-decibel tones. It uses a microprocessor circuit to create 27 distinctive tones. A single tone may be selected by setting a miniature dip switch within the unit. The Adaptatone Millennium can be activated from a 24 Vdc external voltage source such as an output of a PLC or Fire/Security panel.

Standard Features

- Diode Polarized
- Stand-alone, 27 tone capability - no additional tone modules needed
- Four 3-pulse temporal tones
- New "soft" tones
- Single Input, Single Output
- Weatherproof
- Corrosion-resistant heat-flowed epoxy finish
- Captive Components
- Speaker can be rotated and locked in any horizontal direction
- Signal activates directly from a supervised output

Application

The 5530MD-24AW is designed for industrial applications requiring high decibel output and electrical supervision of signaling circuit field wiring. The signal may also be used for unsupervised signaling applications. Typical applications include emergency warning systems, plant evacuation and security intrusion alarms, process monitoring, shift start-and-dismissal horns, and paging signals.

Installation

The 5530MD-24AW is designed for either 1/2" (13 mm) conduit or surface mounting.

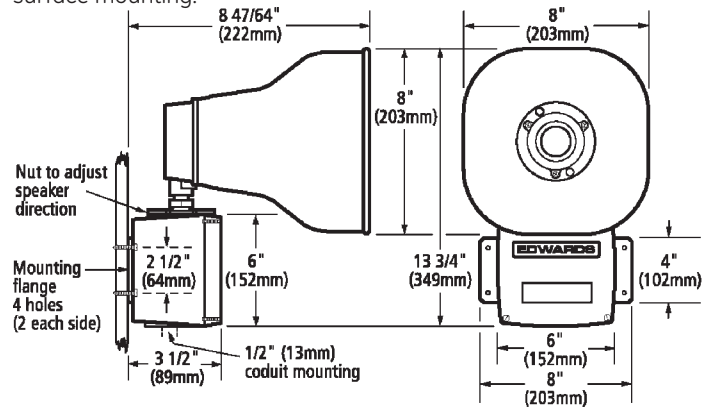

Multiple Tone Signal

5530MD-24AW



U.S.
T 888-378-2329
F 866-503-3996

Canada
T 519 376 2430
F 519 376 7258

Asia
T 852 2907 8108
F 852 2142 5063

Australia
T 61 3 9259 4700
F 61 3 9259 4799

Europe
T 32 2 725 11 20
F 32 2 721 86 13

Latin America
T 305 593 4301
F 305 593 4300

www.gesecurity.com/est

© 2006 General Electric Company
All Rights Reserved

Programmable Tone Selection

Programming the 5530MD-24AW for the tone or tones selected is accomplished through setting the switches located in the signal base. A tone selection chart is provided in the cover of each unit. In some cases the signaling task will dictate the tones required. For example, if a paging function is to be performed one of the unique percussive tones (Chime 1 or Chime 2) may be most suitable. Local regulations or standards may require specific tones such as siren, horn, hi-lo. In some cases varying ambient noise may necessitate on-site evaluation of all available tones to select the most suitable tone. On-site volume control is also available by adjusting the volume control in the base.

Tone	Description	dB Ratings at 10 Ft.*
Ding-Dong	Percussive pairs of 700 and 570 Hz tones, each damped to zero	98
Warble	575 and 770 Hz alternately, 87 ms each	104
Siren	600-1250 Hz up and down sweep in 8 Sec.	110
Stutter Percussive	470 Hz, 83 ms on, 109 ms off	99
Slow Whoop	600-1250 Hz upward sweep n 4 seconds	110
Beep	470 Hz, 0.55 seconds on, 0.55 seconds off	102
Chime 1	700 Hz percussive repeat at 1 Hz	98
Fast Whoop	600-1250 Hz upward sweep in 1 second	110
Hi/Lo	780 to 600 Hz alternately, 0.52 seconds each	105
Rapid Siren	600-1250 Hz up and down sweep in .25 Sec.	107
Yeow	1250-600 Hz downward sweep in 1.6 seconds and repeat	110
Horn	470 Hz continuous	102
Air Horn	370 Hz continuous	102
Dual Tone	450-500 Hz, 0.4 to 0.5 second cycle	103
Chime 2	575 Hz percussive repeat at 1 Hz.	96
3 Pulse Horn	470 Hz, 3 0.5 second pulses separated by 0.5 seconds followed by a 1.5 second delay and repeat	107
3 Pulse Air Horn	370 Hz, 3-0.5 second pulses separated by 0.5 seconds followed by a 1.5 second delay and repeat	107
3 Pulse Dual Tone	450-500 Hz, 0.4 to 0.5 second cycle, 3-0.5 second pulses separated by 0.5 seconds followed by a 1.5 second delay and repeat	105
3 Pulse Chime 2	575 Hz, 3-0.5 second pulses separated by 0.5 seconds followed by a 1.5 second delay and repeat	95
Phasor	416-625 Hz up and down sweep in 13ms	102
Telephone	570 and 770 Hz alternately 50ms. each for 1.2 sec., 1.5s delay	103
Staircase	440-2000 Hz up and down steps, 750ms	107
3 Tone Alert	463, 641, and 869 Hz, 200ms each 1 sec delay	106
Presignal Chime	470 Hz percussive repeat at 1.5 Hz	95
NFPA Whoop	422-775 Hz upward sweep 850 ms each, 1 second delay and repeat	104
Westminster	Two measures 411, 520, 407, 312 Hz	98
Three Blind Mice	Four Measures, 787, 714, 625, 952, 333 Hz	101

* Ratings taken in an anechoic chamber with signal volume control set at maximum and measurements made on an "A" weighted scale with peak hold.

Specifications

Output	15 Watts to 110 dB @ 10 ft
Construction	Heavy-duty zinc cast
Operating Voltage	20-31 Vdc
Standby Current	0.10 amps
Signal On	
Operating Current	0.80 amps
Agency Listings	UL & ULC Listed for indoor and outdoor applications

Ordering Information

Catalog Number	Description	Ship Wt. lb (kg)
5530MD-24AW	Polarized Multiple Tone Signal	25.0 (11.5)



imagination at work